

EC TYPE-EXAMINATION CERTIFICATE

(module B)

according to Directive 94/25/EC
on the approximation of the laws, regulation and administrative provisions of the Member States
relating to recreational craft, as last amended by Directive 2003/44/EC.

- Type Examination Certificate Number : SNCH*94/25*2003/44*0021*00
- Reason for extension : not applicable
1. Make (trade name of manufacturer) : Doosan Infracore
 2. Engine family type : L136
Parent engine type : L136
Engine types within the family : Not applicable
 3. Specification of the craft to be propelled by the engine : Category A, B, C
 4. Means of identification of the type if marked on the recreational craft / component and location of that marking : serial number engraved on the left side of the engine block;
type, model name and EC marking stamped on the aluminium plate on the head cover;
 5. Name and address of manufacturer : Doosan Infracore Co. Ltd.
7-11, Hwasu-dong, Dong-gu,
Incheon, Korea
Name and address of manufacturer's authorized representative (if any) : ---
 6. Manufacturer's technical documentation enabling the conformity of the product : ref. no. 2003/44/EC-2K6-L136-EXT00
 7. Number of test report including the exhaust emission test results : 83-412-133013603-300 TÜV Rheinland Luxemburg

8. Emission test results on test cycle

 E1 E3 E4 E5*Limit values*

CO	:	2.08 g/kWh	5.0 g/kWh
HC	:	0.14 g/kWh	1.7 g/kWh
NOx	:	8.81 g/kWh	9.8 g/kWh
Particulates	:	0.43 g/kWh	1.0 g/kWh

P_N (rated power in kW): 116.8

9. Assigned Notified Body : Société Nationale de Certification et d'Homologation
 Notified Body No : 499

Place and Date : Sandweiler, July 03rd, 2006

Stamp and Signature :



Claude LIESCH
 Conseiller de direction

10. Remarks:

This certificate is valid only with the notified body carrying out product checks at random intervals (module C) or in combination with a valid certificate for module D, E or F according to this Directive.

Manufacturer : Doosan Infracore Co., Ltd.
Engine type : L136

TEST REPORT

(MODULE B)

Recreational craft – exhaust emissions from propulsion engines

**94/25/EC as last amended by 2003/44/EC
Annex I B.**

and

EN ISO 8178-1:1996

Previously granted	
EC - type approval	: ---

Structure of report:

0. General information
1. Test information
2. Test minutes
3. Remarks concerning tested object(s)
4. Appendices
5. Statement of conformity

Manufacturer : Doosan Infracore Co., Ltd.
Engine type : L136

0. General information

- 0.1 Make (trade name of the manufacturer) : Doosan Infracore
- 0.2 Engine type : L136
- Parent engine(s) : L136
Family engine(s) : Not applicable
- 0.3 Specification of craft to be propelled by the engine : A, B and C
- 0.4 Name and address of the manufacturer : Doosan Infracore Co., Ltd.
- 0.5 Order issued by (if different from manufacturer) : Not applicable
- 0.6 No. of technical documentation : 2003/44/EC-2K6-L136-EXT00
date of issue : May 18, 2006
date of last amendment : ---

1. Test information

- 1.1 Test object(s)
- Version : L136
Identification number : 601328
- 1.2 Test date : March 23, 2006
- 1.3 Test site : Doosan Infracore Test Lab., Incheon, Korea
- 1.4 Remarks : The results of the test refer exclusively to the object(s) mentioned under point 1.1 of this report.

~~The engine type has been tested according to the amendments mentioned in Appendix 0.~~

~~The actual test of the engine was not required and results of the previous tests are still valid.~~

Manufacturer : Doosan Infracore Co., Ltd.
Engine type : L136

2. Test minutes

2.1 Test facilities : The test equipment used was in compliance with the requirements of the directive/standard.

2.2 Test results : It was verified that the engine was manufactured in conformity with the above-mentioned technical documentation and met the provisions of Annex I B. of this Directive.

See Appendix 1 for details.

2.3 Dynamometer

Make : ZOLLNER
Type : GPM4/330/300/01

3. Remarks concerning tested object(s) : All versions of the type as stated in the technical documentation are covered with the tested version(s) and test object(s) respectively.

4. Appendices

1 Test results

5. Statement of conformity

The technical documentation and the type described there comply with the requirements in the above- mentioned directive.

Luxembourg, June 12, 2006
SOK



Dipl.-Ing. C. Lee

Manufacturer : Doosan Infracore Co., Ltd.
Engine type : L136

Test results

Appendix 1

- 1. Information concerning the conduct of the test(s)
 - 1.1 Reference fuel used for test : Diesel
 - 1.1.1. Make(s) : SK Corporation
 - 1.1.2. Cetane number : 54
 - 1.1.3. Sulphur content : 8.4 mg/kg
 - 1.1.4. Density at 15°C : 833.0 kg/m³
 - 1.2. Lubricant
 - 1.2.1. Make(s) : Total Isu Oil Co., Ltd.
 - 1.2.2. Type(s) : RUBIA 6600 15W40
 - 1.3. Engine driven equipment (if applicable) : Not applicable
 - 1.3.1. Enumeration and identifying details : Not applicable
 - 1.3.2. Power absorbed at indicated engine speeds (as specified by the manufacturer) : Not applicable

Equipment	Power P _{AE} (kW) absorbed at various engine speeds (*)				
	Low idle	Intermediate			Rated
	rpm	rpm	rpm	rpm	rpm
--	--	--	--	--	--
--	--	--	--	--	--
--	--	--	--	--	--
Total	--	--	--	--	--

(*) must not be greater than 10% of the power measured during the test

- 1.4. Engine performance
 - 1.4.1. Engine speeds
 - Idle [min⁻¹] : 725
 - Intermediate [min⁻¹] : 1386/1760/2002
 - Rated [min⁻¹] : 2200

Manufacturer : Doosan Infracore Co., Ltd.
Engine type : L136

1.4.2. Engine power

Conditions	Power setting (kW) absorbed at various engine speeds				
	Low idle	Intermediate			Rated
Maximum power measured on test (P_M) (kW) (a)	--	29.9	60.0	87.8	116.8
Total power absorbed by engine driven equipment as per section 1.3.2 (kW) (b)	--	--	--	--	--
Net engine power (kW) (c)	--	29.9	60.0	87.8	116.8
c = a + b					

1.5. Emission levels

1.5.1. Emission cycle and dynamometer settings used :

cycle E3:

Mode number	1	2	3	4
Speed, %	100	91	80	63
Power, %	100	75	50	25
Weighting factor	0.2	0.5	0.15	0.15

1.5.2. Emission test results on the test cycle

Limit values*

CO	: 2.08 g/kWh	5.0
HC	: 0.14 g/kWh	1.7
NOx	: 8.81g/kWh	9.8
PT	: 0.43 g/kWh	1.0

* Limit values:

Type	$CO = (A + B/P_N^n)$			$HC = (A + B/P_N^n)$			NOx	PT
	A	B	n	A	B	n		
<i>Two-stroke</i>	150.0	600.0	1.0	30.0	100.0	0.75	10.0	-
<i>Four-stroke</i>	150.0	600.0	1.0	6.0	50.0	0.75	15.0	-
<i>Compression ignition</i>	5.0	0	0	1.5	2.0	0.5	9.8	1.0

P_N : rated power in kW = 116.8

EC TYPE-EXAMINATION CERTIFICATE

(module B)

according to Directive 94/25/EC
on the approximation of the laws, regulation and administrative provisions of the Member States
relating to recreational craft, as last amended by Directive 2003/44/EC.

- Type Examination Certificate Number : SNCH*94/25*2003/44*0021*00
- Reason for extension : Not applicable
1. Make (trade name of manufacturer) : Doosan Infracore
2. Engine type : L136
- Parent engine(s) : L136
- Family engine(s) : Not applicable
3. Specification of the craft to be propelled by the engine : A, B and C
4. Means of identification of the type if marked on the ~~recreational craft~~ component and location of that marking
- Serial number : Engraving on the left side of the Engine block
- Type and model name : Stamped on the aluminum plate on the head cover
- EC marking : Stamped on the aluminum plate on the head cover
5. Name and address of manufacturer : Doosan Infracore Co., Ltd.
7-11, Hwasu-dong, Dong-gu,
Incheon, Korea
- Name and address of manufacturer's authorized representative (if any) : Not applicable

6. Manufacturer's technical documentation enabling the conformity of the product : ref. no. 2003/44/EC-2K6-L136-EXT00
7. Number of test report including the exhaust emission test results : 83-412-133013603-300 by TÜV Rheinland Luxembourg
8. Emission test results on test cycle
 E1 E3 E4 E5 *Limit values*
- | | | |
|--------------|--------------|-----------|
| CO | : 2.08 g/kWh | 5.0 g/kWh |
| HC | : 0.14 g/kWh | 1.7 g/kWh |
| NOx | : 8.81 g/kWh | 9.8 g/kWh |
| Particulates | : 0.43 g/kWh | 1.0 g/kWh |
- P_N: rated power in kW -- 116.8
9. Assigned Notified Body : Société Nationale de Certification et d'Homologation
 Notified Body No : 499
 Place and Date : Sandweiler
- Stamp and Signature : Claude LIESCH
 Conseiller de direction
10. Remarks:
 This certificate is valid only with the notified body carrying out product checks at random intervals (module C) or in combination with a valid certificate for module D, E or F according to this Directive.

	ENGINE FAMILY DESCRIPTION	Page No: 1
		Issue Date: 05/18/2006
	Engine Family: L136	Revision No:
		Revision Date:

Information Document No. 2003/44/EC-2K6-L136-EXT00

Relating to type-approval and referring to measures against the emission of gaseous and particulate pollutants from I.C engines to be installed in personal watercraft
(Directive 94/25/EC as last amended by directive 2003/44/EC)

Engine type : L136

0. **General**

- 0.1. Make (Name of undertaking) : Doosan Infracore
- 0.2. Type and commercial description of the parent-and (if applicable) of the family engine(s) : Parent: L136, Family: N / A
- 0.3. Manufacturer's Type coding as marked on the engine(s) : See point 0.6
- 0.4. Specification of craft to be propelled by the engine : Category A, B and C
- 0.5. Name and address of manufacturer : Doosan Infracore Co., Ltd.
7-11, Hwasu-dong, Dong-gu,
Incheon, Korea
- Name and address of manufacturer's authorized representative (if any) : N/A

0.6.	Location, coding and method of affixing of the engine identification		
	Location	On the left side of the Engine block	On the left side of the Engine block
	Coding	Serial No.	Type & Model Name
	Method of affixing	Engraving	Stamped on the aluminum plate

0.7. Location and method of affixing of the EC approval mark

- Location : On the left side of the Engine block
- Method of affixing : Stamped on the aluminum plate

0.8. Address(es) of assembly plant(s) : See point 0.5

	ENGINE FAMILY DESCRIPTION	Page No: 2
		Issue Date: 05/18/2006
	Engine Family: L136	Revision No:
		Revision Date:

Appendix

1. Essential characteristics of the parent engine(s) (see Appendix 1)
2. Essential characteristics of the engine family (see Appendix 2)
3. Essential characteristics of engine types within the family (see Appendix 3) – N / A
4. Characteristics of engine – related parts of the craft – N / A
5. Photographs of the parent engine (see Attachment 1)
6. Location of engine part identification numbers (see Attachment 2)
7. Revision history (see Attachment 3)

	ENGINE FAMILY DESCRIPTION	Appendix 1 Page No: 1
		Issue Date: 05/18/2006
	Engine Family: L136	Revision No:
		Revision Date:

Appendix 1

ESSENTIAL CHARACTERISTICS OF THE PARENT ENGINE

1. Description of Engine

1.1.	Manufacturer	:	Doosan Infracore
1.2.	Manufacturer's engine code	:	L136
1.3.	Cycle	:	Four stroke
1.4.	Bore	:	111 mm
1.5.	Stroke	:	139 mm
1.6.	Number and layout of cylinders		
	Number	:	6 cylinders
	Layout of cylinders	:	In-line, from fly wheel side 1-5-3-6-2-4
1.7.	Engine capacity	:	8,071 cm ³
1.8.	Rated speed	:	2,200 rpm
1.9.	Maximum torque speed	:	1,400 rpm
1.10.	Volumetric compression ratio	:	17.6 (±0.2): 1
1.11.	Combustion system description	:	Direct injection
1.12.	Drawing(s) of combustion chamber and piston crown	:	See Fig. 8
1.13.	Minimum cross sectional area of inlet and outlet ports		
	Inlet port	:	1,683±5 mm ²
	Outlet port	:	1,612±5 mm ²
1.14.	Cooling system		
1.14.1.	Liquid		
1.14.1.1.	Nature of liquid	:	Water
1.14.1.2.	Circulating pump(s)	:	yes / no
1.14.1.3.	Characteristics or make(s) and type(s)		
	Make	:	Wooil precision Industries Ltd.
	Type	:	Centrifugal type pump
1.14.1.4.	Drive ratio(s)	:	1.375:1
1.14.2.	Air	:	N / A

	ENGINE FAMILY DESCRIPTION	Appendix 1 Page No: 2
		Issue Date: 05/18/2006
	Engine Family: L136	Revision No:
		Revision Date:

1.15.	Temperature permitted by the manufacturer	
1.15.1.	Liquid cooling : maximum temperature at outlet	: 376 K
1.15.2.	Air cooling : reference point Maximum temperature at reference point	: N / A
1.15.3.	Maximum charge air outlet temperature of the inlet intercooler	: N / A
1.15.4.	Maximum exhaust temperature at the point in the exhaust pipe(s) adjacent to the outer flange(s) of the exhaust manifold(s)	: 910 K
1.15.5.	Lubricant temperature	: Max. 388K
1.16.	Pressure charge	: yes / no
1.17.	Intake system : maximum allowable intake Depression at rated engine speed and at 100% load	: 7.8 kPa
1.18	Exhaust system : maximum allowable exhaust backpressure at rated engine speed and at 100% load	: 10.8 kPa
2.	ADDITIONAL ANTI-POLLUTION DEVICE	: N / A
3.	FUEL FEED FOR DIESEL ENGINES	
3.1.	Feed pump	
	Pressure or characteristics diagram	: See Fig. 4
3.2	Injection system	
3.2.1	Pump	
3.2.1.1	Make	: DPICO
3.2.1.2	Type	: In-line type / KP-PES6AD95B410RS2
3.2.1.3	Delivery: $84 \pm 2.5 \text{ mm}^3$ and $92 \pm 2.5 \text{ mm}^3$ per stroke or cycle at full injection at engine speed of 2,200 rpm (rated point) and 1,400 rpm (maximum torque) respectively. Mention the method used: on engine	
3.2.1.4	Injection advance	
3.2.1.4.1	Injection advance curve	N / A
3.2.1.4.2	Timing	: Control by BTDC 20°
3.2.2	Injection piping	
3.2.2.1	Length	: 620 mm
3.2.2.2	Internal diameter	: 2.0 mm
3.2.3	Injector	
3.2.3.1.	Make	: Delphi
3.2.3.2	Type	: Pinttle type / 9134-153
3.2.3.3	Opening pressure or characteristic diagram	: 21 MPa (214kg/cm ²)

	ENGINE FAMILY DESCRIPTION	Appendix 1 Page No: 3
		Issue Date: 05/18/2006
	Engine Family: L136	Revision No:
		Revision Date:

- 3.2.4 Electric Control unit : N / A
- 3.3 Cold start system : N / A
- 4. FUEL FEED FOR PETROL ENGINES : N / A**
- 5. VALVE TIMING**
- 5.1. Maximum lift and angles of opening and closing in relation to dead centers or equivalent data
- Inlet lift : 7.95 mm
- Outlet lift : 8.11 mm
- Inlet open : 16 [°BTDC]
- Inlet closed : 36 [°ABDC]
- Outlet open : 46 [°BBDC]
- Outlet closed : 14 [°ATDC]
- 5.2. Reference and/or setting ranges
- Inlet valve clearance 0.3 mm / cold condition
- Outlet valve clearance 0.3 mm / cold condition
- 5.3. Variable valve timing system (if applicable and where intake and/or exhaust) : N / A
- 6. PORTING CONFIGURATION**
- 6.1. Position, size and number
- Intake valve : 1 ea (dia. 48.5mm) per cylinder
- Exhaust valve : 1 ea (dia. 46mm) per cylinder
- 7. IGNITION SYSTEM : N / A**

	ENGINE FAMILY DESCRIPTION	Appendix 2 Page No: 1
		Issue Date: 05/18/2006
	Engine Family: L136	Revision No:
		Revision Date:

Appendix 2

ESSENTIAL CHARACTERISTICS OF THE ENGINE FAMILY

1. COMMON PARAMETERS

- | | | |
|------|--|----------------------------------|
| 1.1. | Combustion cycle | : 4 stroke cycle |
| 1.2. | Cooling medium | : Water |
| 1.3. | Method of air aspiration | : Natural aspirated |
| 1.4. | Combustion chamber type/design | : See Fig. 1 & See Fig. 2 |
| 1.5. | Valve and porting – configuration, size and number | |
| | Intake | : 1ea (dia. 48.5mm) per cylinder |
| | Exhaust | : 1ea (dia. 46mm) per cylinder |
| 1.6. | Fuel system | : Direct Injection |
| 1.7. | Engine management systems | : See attachment 2 |
| | Proof of identity pursuant to drawing number(s) | |
| | - Piston | |
| | - Combustion chamber | |
| | - Cam shaft | |
| | - Diagram of Fuel System | |
| | - Injection pump | |
| | - Injection nozzle | |
| | - Cylinder head | |
| 1.8. | Exhaust after – treatment system | : N / A |

	ENGINE FAMILY DESCRIPTION	Appendix 2 Page No: 2
		Issue Date: 05/18/2006
	Engine Family: L136	Revision No:
		Revision Date:

2. ENGINE FAMILY LISTING

- 2.1. Name of engine family : L136
- 2.2. Specification of engines within this family : See below chart
- 2.3. Engine durability considered acceptable *¹ : yes / ~~no~~
- 2.4. Engine owner's manual available *² : yes / ~~no~~

*¹: As described in Annex I section B. 3.

*²: As described in Annex I section B. 4.

	Parent engine * ¹
Engine type	L136
No. of cylinders	6
Rated speed (rpm)	2,200
Fuel delivery per stroke (mm ³)	84±2.5
Rated net power (kW)	118
Maximum torque speed (rpm)	1400
Fuel delivery per stroke (mm ³)	92±2.5
Maximum torque (Nm)	577
Low idle speed (rpm)	725±25
Cylinder displacement (in % of parent engine)	100

*¹ for full details See Appendix 1.

	ENGINE FAMILY DESCRIPTION	Attachment 1 Page No: 1
		Issue Date: 05/18/2006
	Engine Family: L136	Revision No:
		Revision Date:

**Attachment 1
PHOTOGRAPHS OF THE PARENT ENGINE**

**Block: Serial Number (Engraving)
Name plate: Type & Model name**

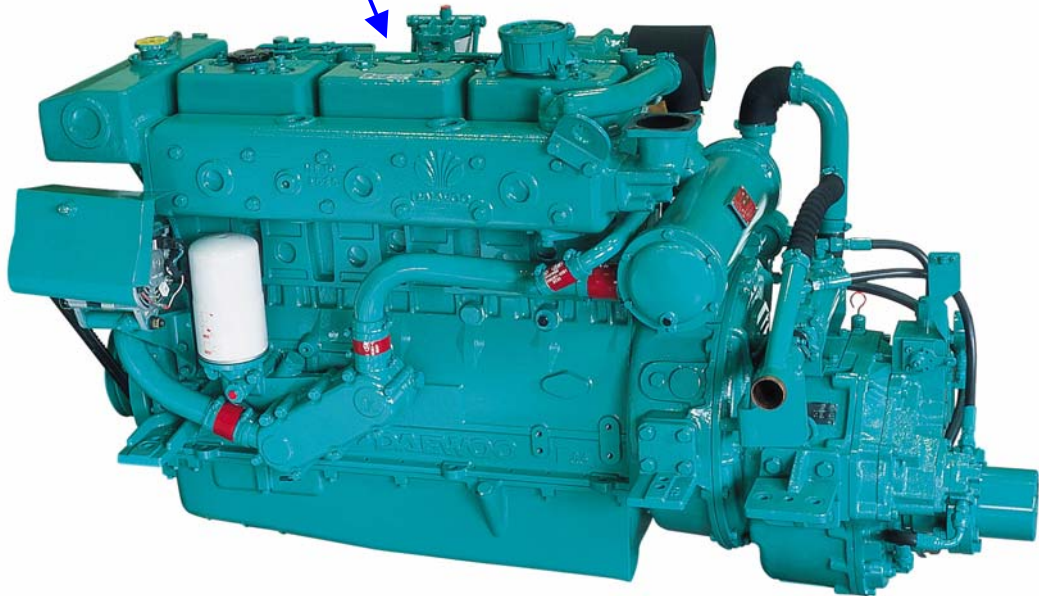

	ENGINE FAMILY DESCRIPTION	Attachment 2 Page No: 1
		Issue Date: 05/18/2006
	Engine Family: L136	Revision No:
		Revision Date:

Attachment 2
LOCATION OF ENGINE PART IDENTIFICATION NUMBERS

Fig. 1. Piston

Marking	0779
---------	------

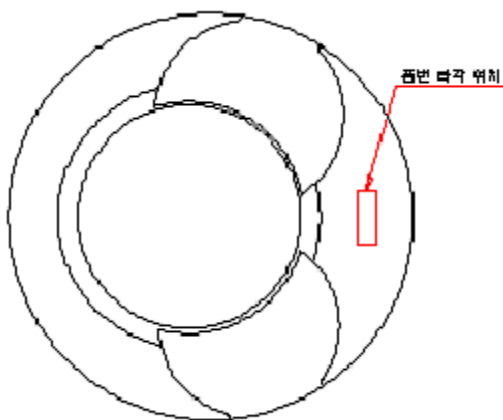
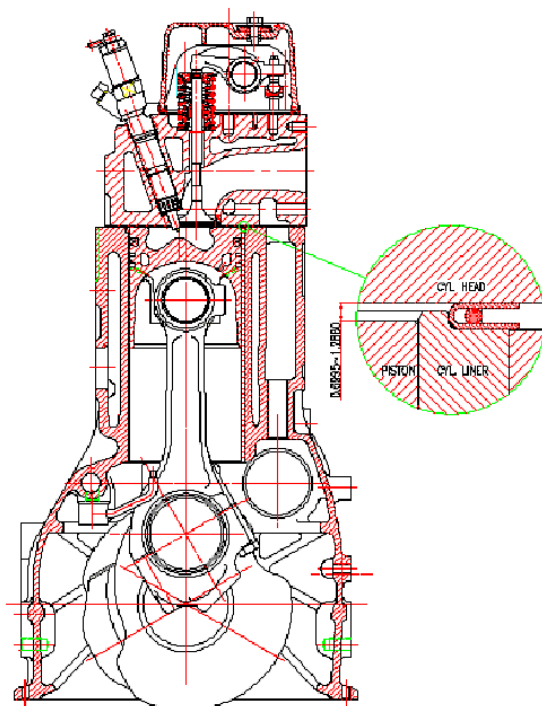

Fig. 2. Combustion chamber



	ENGINE FAMILY DESCRIPTION	Attachment 2 Page No: 3
		Issue Date: 05/18/2006
	Engine Family: L136	Revision No:
		Revision Date:

Fig. 5. Injection Pump

Marking	101605-9292
---------	-------------

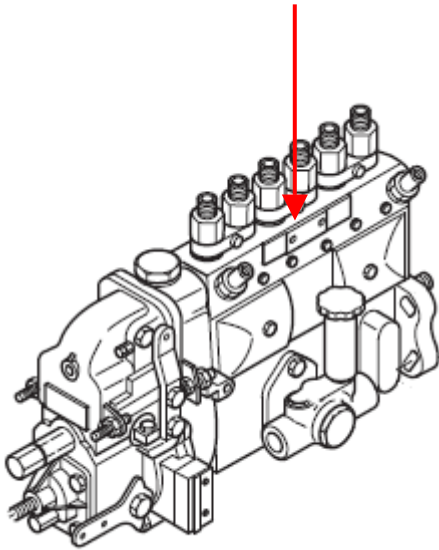

Fig. 6. Injection Nozzle

Marking	LRC6703703DZ3
---------	---------------





	ENGINE FAMILY DESCRIPTION	Attachment 2 Page No: 4
		Issue Date: 05/18/2006
	Engine Family: L136	Revision No:
		Revision Date:

Fig. 7. Cylinder Head

Marking	3 0 8 7
---------	---------

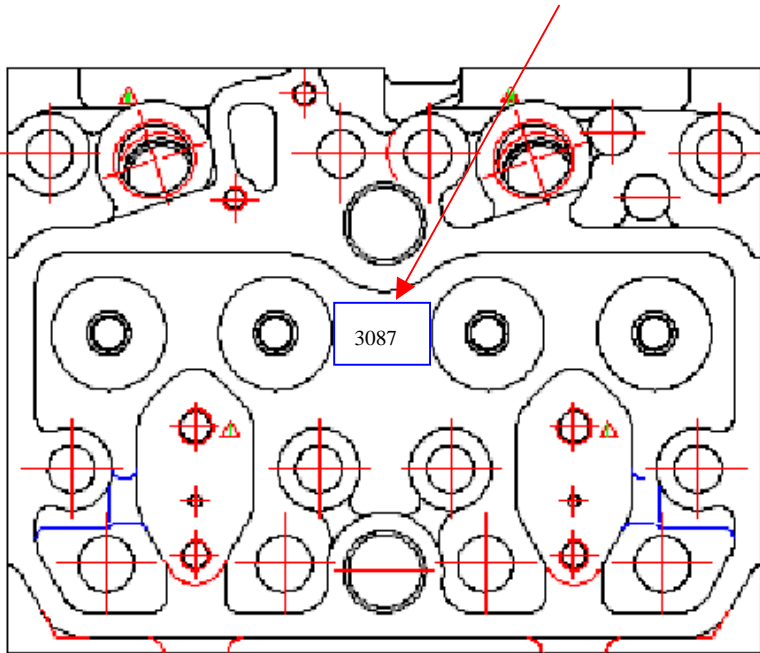

	ENGINE FAMILY DESCRIPTION	Attachment 3 Page No: 1
		Issue Date: 05/18/2006
	Engine Family: L136	Revision No:
		Revision Date:

**Attachment 3
REVISION HISTORY**

REV. DATE	REV. NO.	DESCRIPTION	PAGE NO.